

Hutch

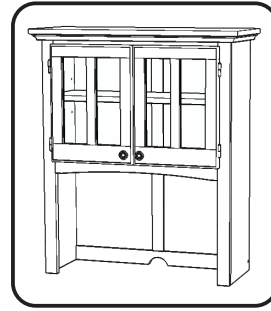

Hutch



IMPORTANT

Carefully remove all the parts from the carton and place them individually on a soft cloth to prevent scratches or other damage.

Carefully and strictly follow these assembly instructions to ensure a completed product as designed.

Do not use power tools above 8 volts to assemble.

Part List



A.  
Top  
1 pc.

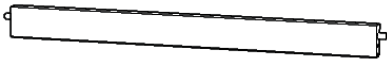

F.  
Back Stretcher  
1 pc.



G.  
Back Stretcher  
1 pc.



I.  
Fixed Shelf  
1 pc.



B.  
Side Panel  
1 pc.

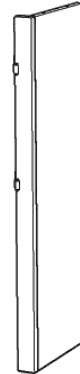

C.  
Side Panel  
1 pc.

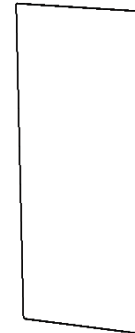

D.  
Back Panel  
2 pcs.



E.  
Back Upright  
1 pc.



H.  
Front Stretcher  
1 pc.

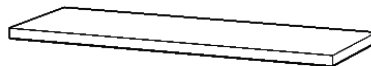

J.  
Shelf  
1 pc.

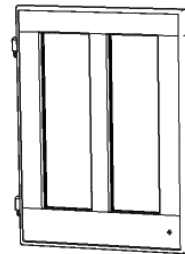

K.  
Door  
1 pc.



L.  
Door  
1 pc.

Hardware List



Cam Lock  
14 pcs. (+2 extra)



M3.5x16  
Wood Screw for Back Panel  
8 pcs. (+1 extra)



Adjustable Pin  
4 pcs. (+1 extra)

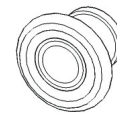

Knob  
2 pcs.



Cam Lock Screw  
14 pcs. (+1 extra)



M4x13  
Wood Screw for Bracket  
8 pcs. (+1 extra)



M4x25  
Machine Screw  
2 pcs.



Bracket  
2 pcs.

Tool(s) required for assembly: Phillips screwdriver, Drill (8 volts or less), 3/8" Drill Bit

Home Styles Customer Service: [www.homestyles-furniture.com](http://www.homestyles-furniture.com),  
 servicedesk@homestyles-furniture.com, 888-680-7460, 877-831-0319

# Assembly Instructions 2/6

## IMPORTANT

- Use a soft cloth between these parts and the floor.
- Do not use power tools above 8 volts to assemble.
- Do not tighten all the screws until each part is properly assembled.

## STEP 1

Insert Cam Lock Screws into pre-drilled holes in Top (A) and Side Panels (B), (C), then tighten. (See Figure 1)

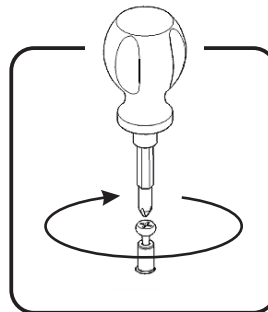
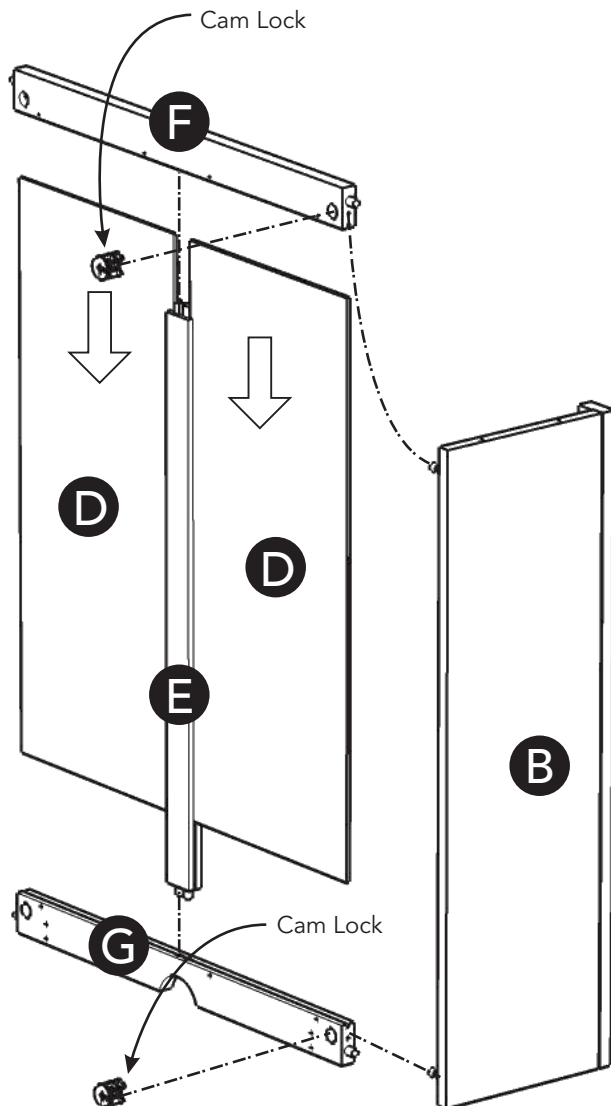
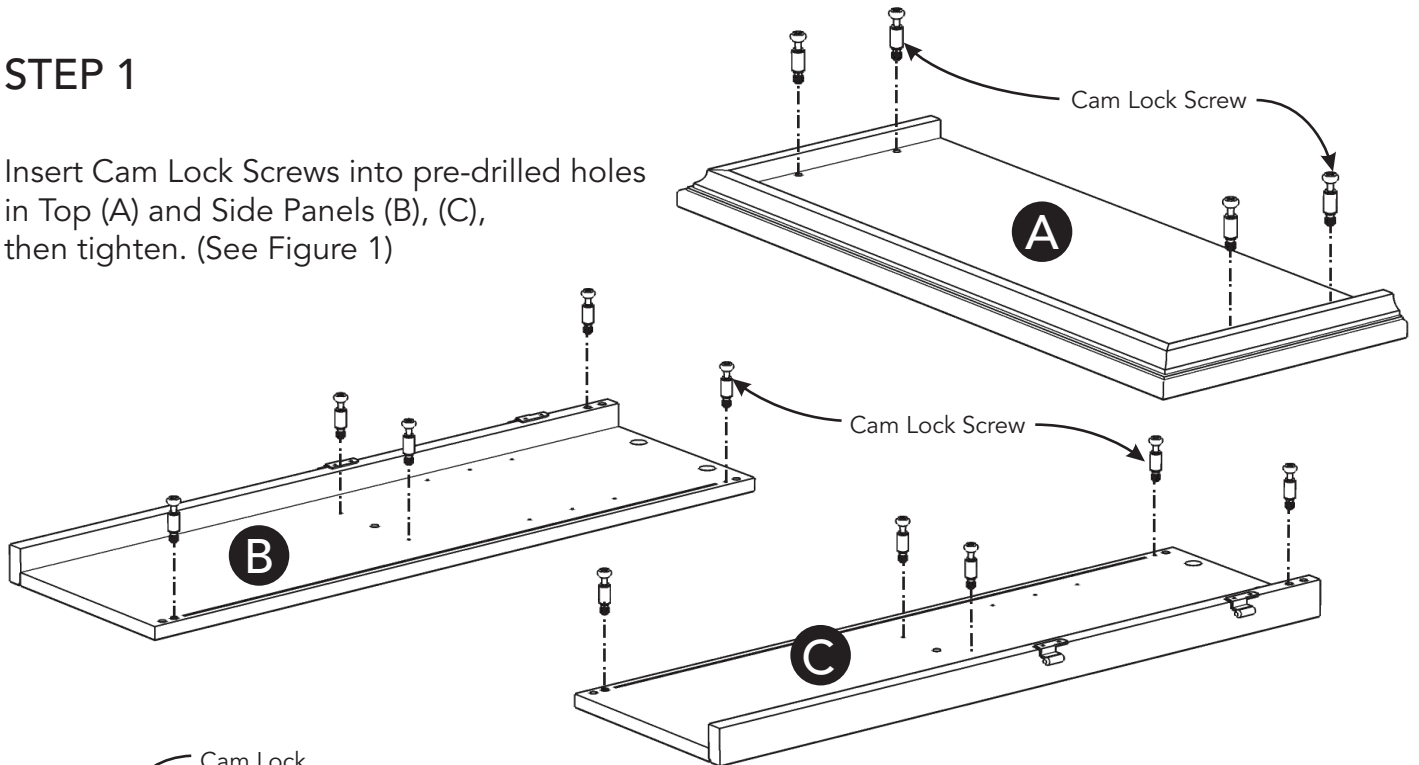

Figure 1

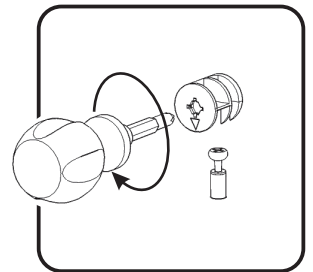

Figure 2

## STEP 2

Attach Back Stretcher (G) to Side Panel (B) with Cam Lock. (See Figure 2)

Attach Back Upright (E) to Back Stretcher (G).

Slide Back Panels (D) into position.

Attach Back Stretcher (F) to unit with Cam Lock.

# Assembly Instructions 3/6

## STEP 3

Attach Fixed Shelf (I) to unit with Cam Locks.

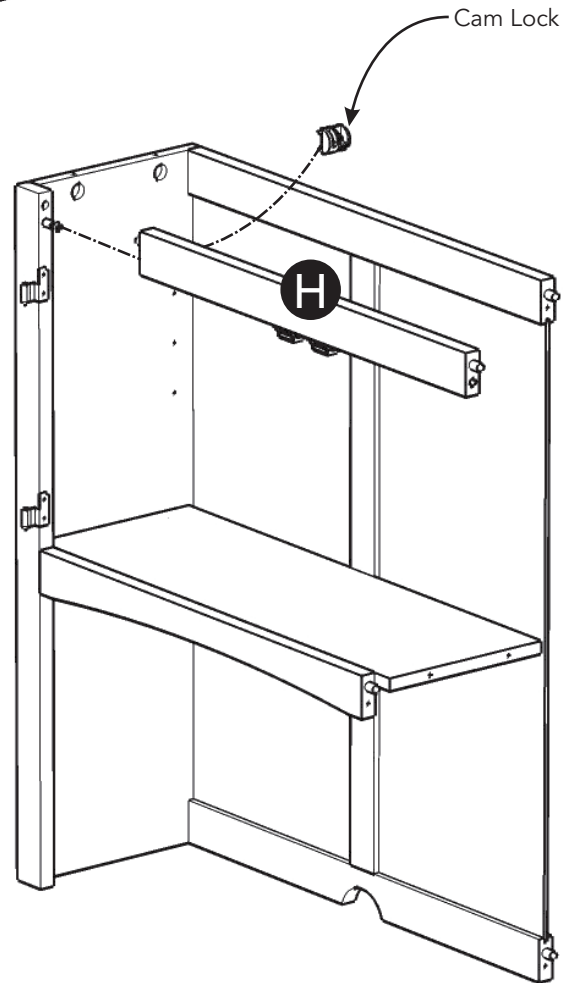
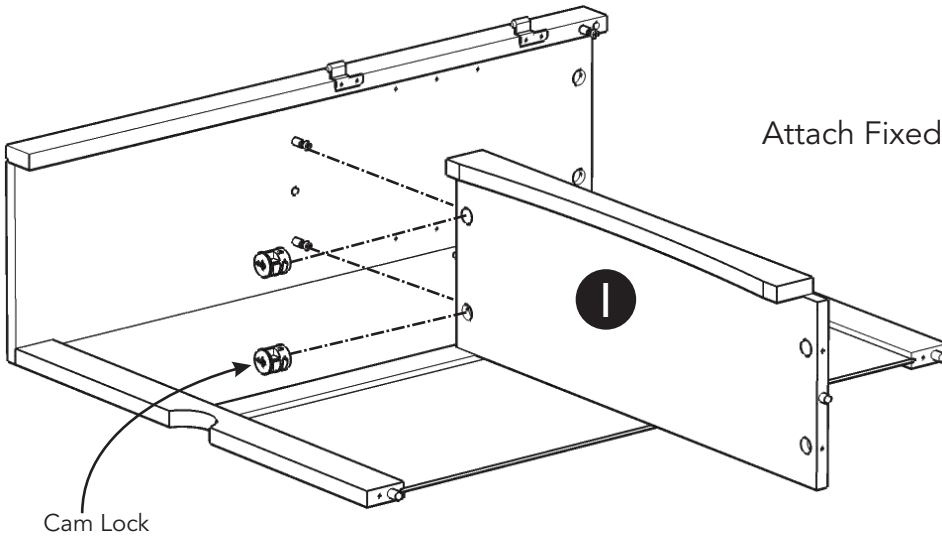

## STEP 4

Attach Front Stretcher (H) to unit with Cam Lock.

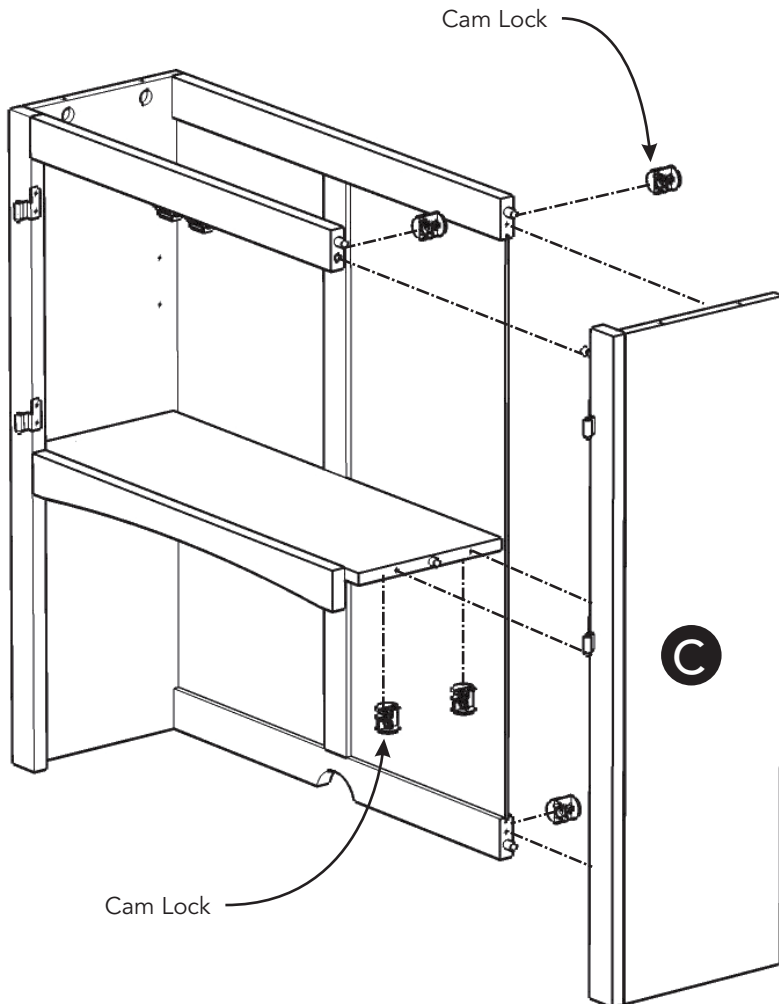

## STEP 5

Attach Side Panel (C) to unit with Cam Locks.

## Assembly Instructions 4/6

### STEP 6

Insert Adjustable Pins into side panels at desired level.

Place Shelf (J) into position.

Attach Doors (K) and (L) to unit by sliding door hinges into side panel hinges. (See Figure 3)

Attach Knobs to Doors (K) and (L) with Machine Screws. (See Figure 4)

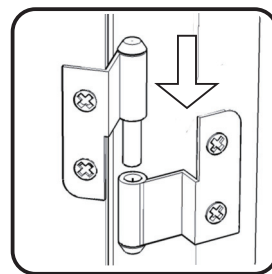
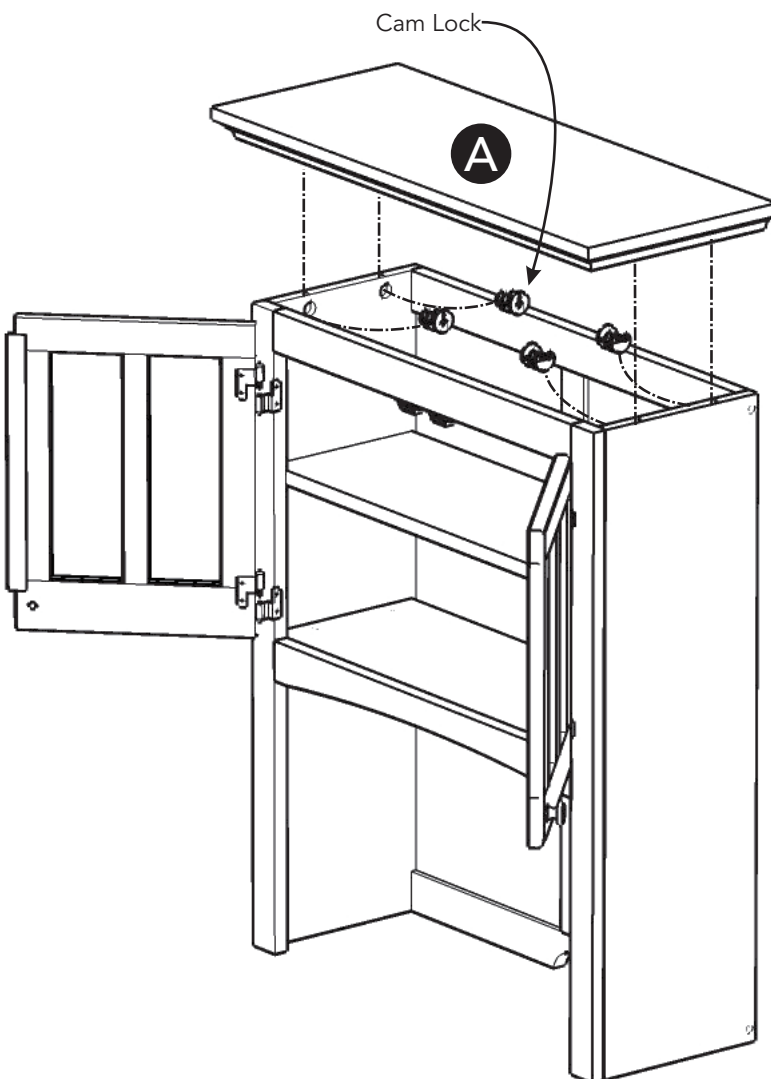
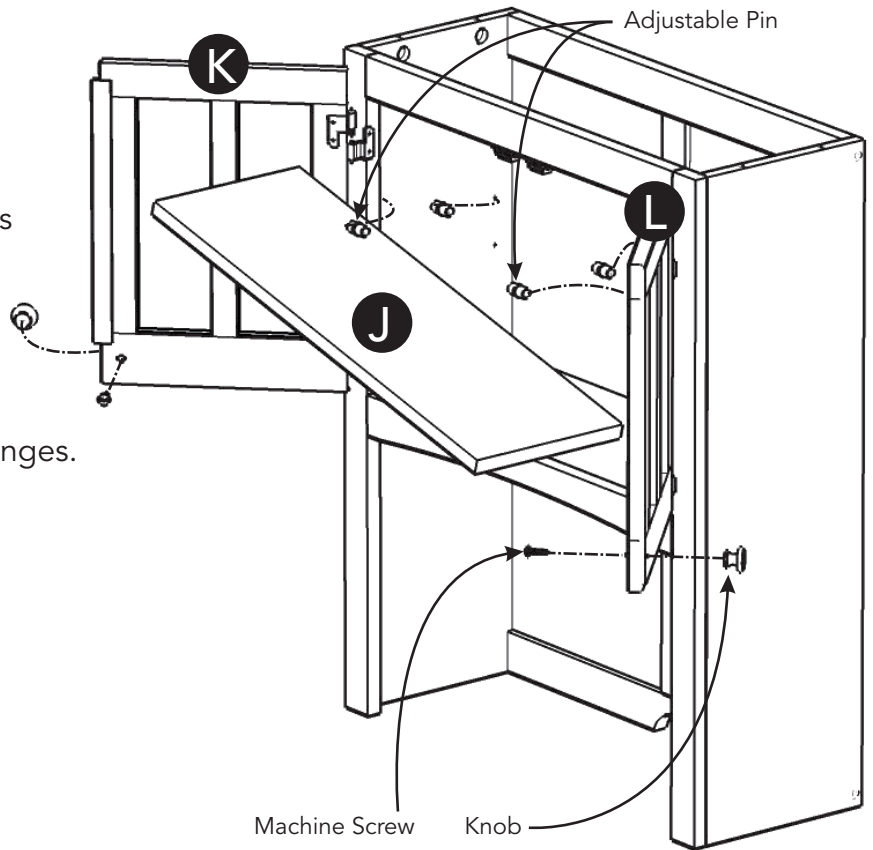

Figure 3

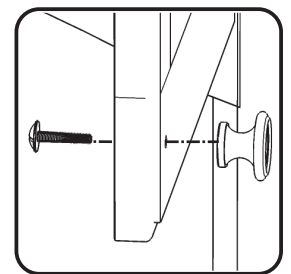

Figure 4

### STEP 7

Attach Top (A) to unit with Cam Locks.

**STEP 8**

Insert Wood Screws for Back Panel into pre-drilled holes in unit.

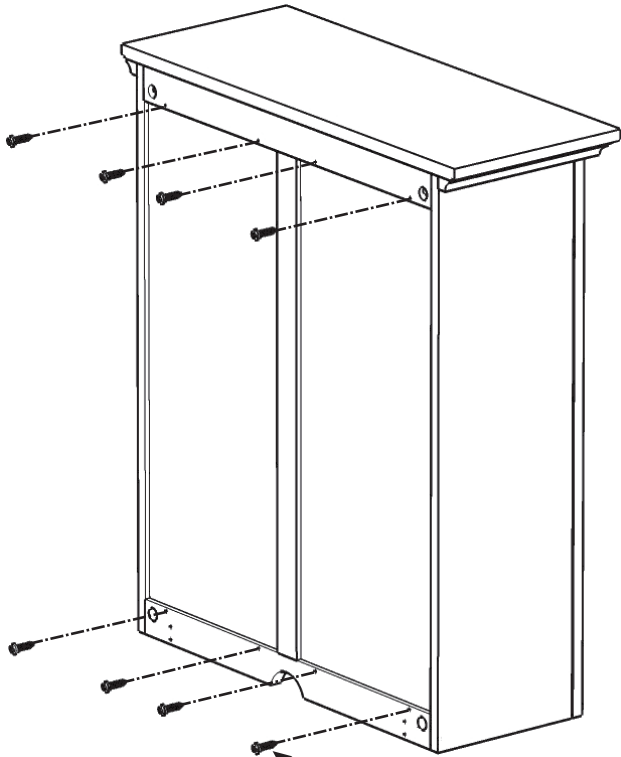

Wood Screw  
for Back Panel

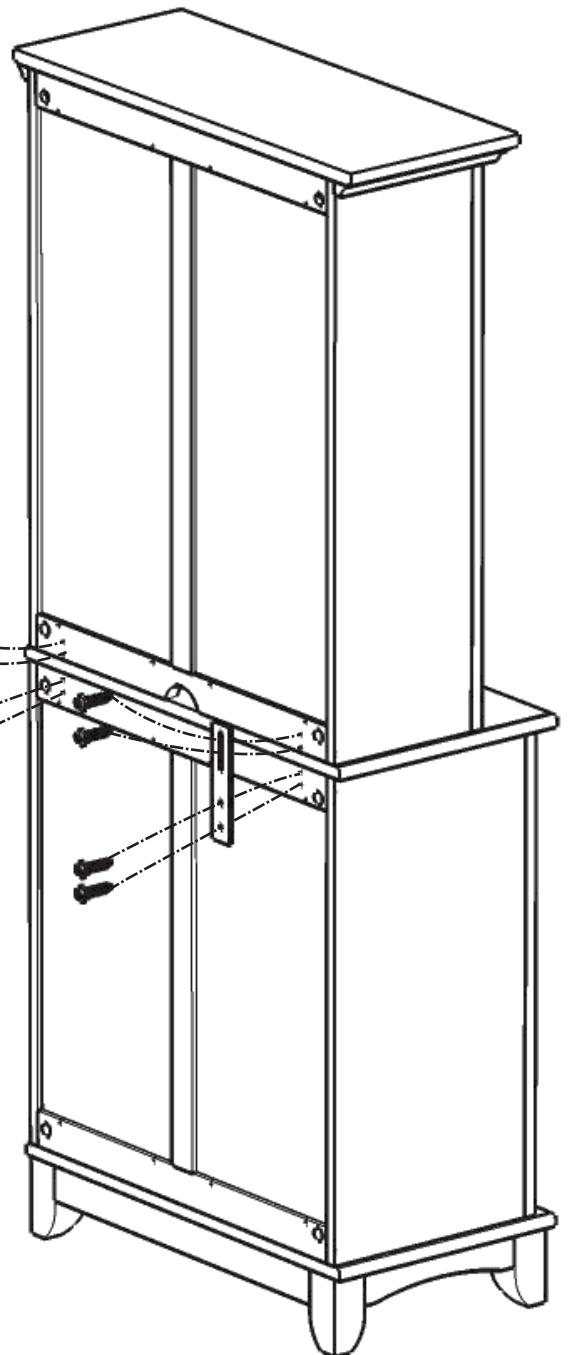

Wood Screw  
for Bracket

Bracket

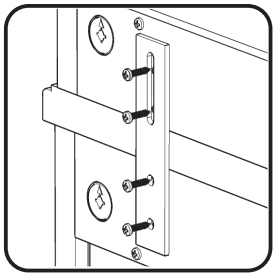

Figure 5

**STEP 9**

Attach Hutch to Buffet with Brackets by inserting Wood Screws for Bracket into pre-drilled holes. (See Figure 5)

# Assembly Instructions 6/6

## IMPORTANT

• To help reduce the risk of the unit tipping over, the Tipover Restraint must be installed following these instructions exactly.

## STEP 10

Place unit at desired location.

Drill a 3/8" hole in wall in-line with pre-drilled hole at top of unit.

Move unit.

Insert Anchor into the wall hole and attach Bracket with Wall Screw.

Attach Bracket at pre-drilled hole at top of unit with Wood Screw.

Move unit back into place.

Slide Tipover Restraint through Bracket on wall and Bracket on unit.  
(See Figure 6)

Put tie end of Tipover Restraint into lock end of Tipover Restraint and pull until tight.

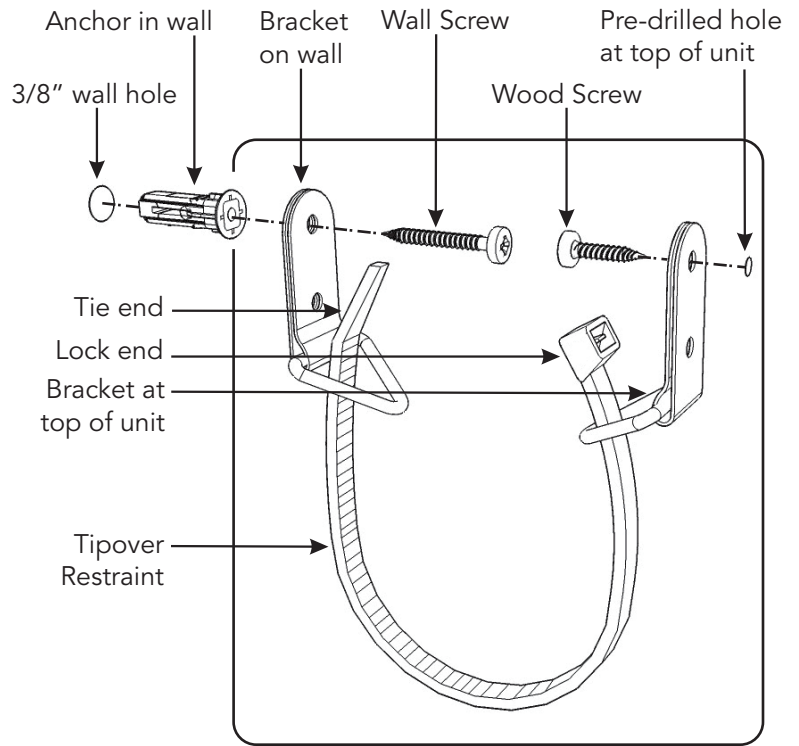
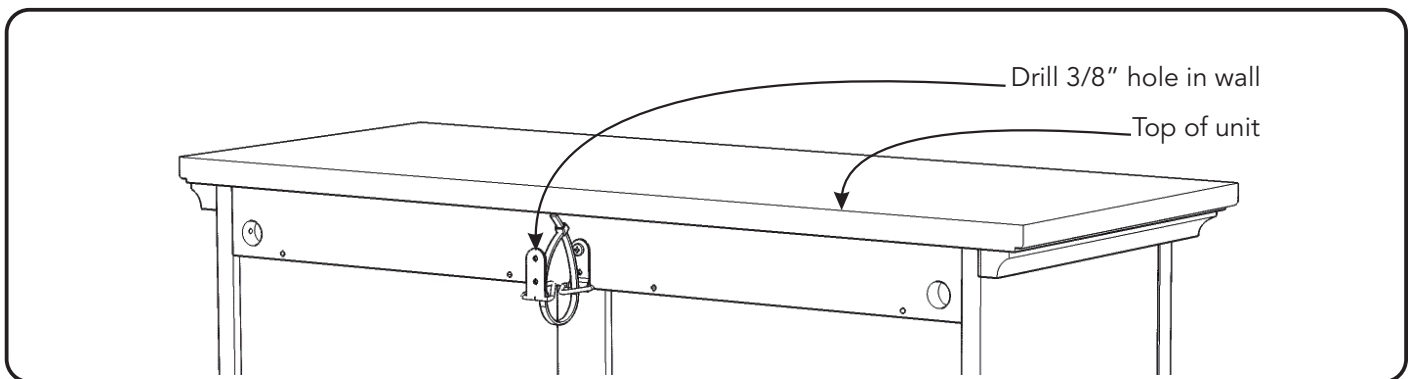
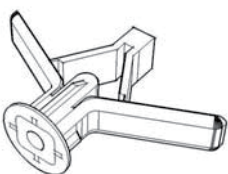

Figure 6



## Hardware List



Anchor  
1 pc. (+1 extra)

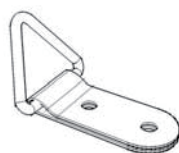

Bracket  
2 pcs. (+1 extra)

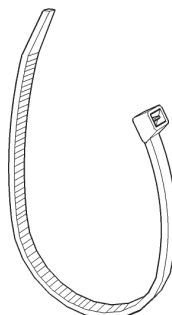

Tipover Restraint  
1 pc. (+1 extra)

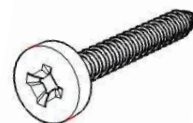

M3.5x40  
Wall Screw  
1 pc. (+1 extra)



M3.5x16  
Wood Screw  
1 pc. (+1 extra)

# CARE INSTRUCTIONS

## NEVER

allow liquids to remain on furniture.  
Absorption causes parts to warp  
and split and finishes to delaminate.

## NEVER

use glass cleaners on  
finished furniture. Ammonia  
chemically attacks the finish.



Do not use power tools  
above 8 volts to assemble.

**PREVENT  
CRACKING**



Do not place  
in direct sunlight.

**PREVENT  
FADING**



Do not write  
directly on surface.

**PREVENT  
MARKING**



Do not place hot  
objects on surface.

**PREVENT  
FINISH DAMAGE**



Do not use rubber  
based placemats.

**PREVENT  
DISCOLORING**



Do not use commercial  
waxes and polishes.

**PREVENT  
YELLOWING**

## CLEAN

with a soft cloth moistened  
in lukewarm soap and water.  
Buff with a dry clean cloth.



Home Styles will provide replacements free of charge for missing or damaged hardware or parts within 30 days of purchase. Digital images of the defective parts may be required. If the product was not purchased from an authorized retail affiliate, Home Styles is under no obligation to provide replacement parts. Parts are not available for fully assembled items nor are parts available for sale. Replacements for missing or damaged hardware or parts may be requested at:

[www.homestyles-furniture.com/customer-service/replacement-parts](http://www.homestyles-furniture.com/customer-service/replacement-parts)

Home Styles Customer Service: [www.homestyles-furniture.com](http://www.homestyles-furniture.com),  
[servicedesk@homestyles-furniture.com](mailto:servicedesk@homestyles-furniture.com), 888-680-7460, 877-831-0319